



IJMRBS

ISSN: 2319-345X

International Journal of Management Research and Business Strategy

www.ijmrbs.org



E-mail

editor@ijmrbs.org

editor.ijmrbs@gmail.com

An Authentication and Fire Alarm System for the Home Based on the Internet of Things

Dr. Seema Bhakuni Meenakshy Poornima

1.ASSOCIATE PROFESSOR,2,3&4.UG SCHOLAR

DEPARTMENT OF ECE, MALLA REDDY ENGINEERING COLLEGE FOR WOMEN, HYDERABAD

ABSTRACT: Ensuring minimum rights and safety of the garment workers has become a burning issue nowadays. The workers of garment factories are facing some labyrinths and broken out of fire is surely one of them. The investors are losing their interest and the prominence of this sector is getting toneless. In this paper, we have propounded a system which is capable to detect fire and can provide the location of the affected region. Raspberry Pi 3 has been used to control which are integrated with a couple of sensors and camera. We have provided a confirmation of the fire suspecting system to avoid any false alarm. The system will immediately send a message along with the image of the affected spot and device location. An admin can confirm or deny the impeachment and if the admin confirms the situation as a breaking out of fire, then the system will immediately raise an alarm and an automatic message will be sent to the

nearby fire brigade.

INTRODUCTION In the earlier days, personal computers were used to handle daily tasks of individuals like mail surfing, access to bank portal, and other things. Nowadays, IoT enabled smart devices like smart mobile phones are being used by them for such tasks due to rapid growth in Internet of Things (IoT). With the inception of IoT, the idea of remotely monitoring objects through the Internet has emerged [1]. When it comes to any textile workhouse, fire accident is a crucial issue to the workers and the investors. At present, many garment factories do not have proper fire prevention and rescue system. Hundreds of factories are vulnerable to fire break out because the factories are very old and lack fire detection technology. Assume there isn't anyone at the garment factory and a fire breaks out. This will not only cause loss for the investors but also there

wouldn't be any data available to investigate the cause and claim any insurance. We have implemented a fire alarming and authentication system with the help of Raspberry Pi 3 which is a credit card sized minicomputer. The system which will continuously record relevant data from Flame sensor, PIR sensor & Gas sensor. A webcam is used to capture an image in case of an intruder and sends the captured image to our email via Wi-Fi. If fire has been detected, the system sends the captured image to the registered email via Wi-Fi and switches ON the sprinkler motor and alarm to alert the fire brigade.

LOW COST AND EFFICIENT SYSTEM

The proposed system uses a Raspberry Pi 3 which is a credit card sized minicomputer that runs on a 5V power source via MicroUSB. Unlike the conventional CCTV (closed circuit Television) system, not only does our system draw less power but the equipment cost too is very low. The cost of implementation of CCTV varies depending upon the size and use of the system [2]. The efficiency of the proposed system increases as the camera used switches ON to capture images only when either an intruder or a fire event is detected; it remains OFF at all other

time. The conventional CCTV system cannot automatically trigger an alarm or sprinkler motors without human intervention. It simply records the video footage 24x7 and stores it in a hard disk (large memory space) which can be damaged in case of a fire accident

LITERATURE REVIEW

Background: Workhouses are vital institutions that provide shelter, accommodation, and support services to individuals in need. These establishments cater to a wide range of residents, including the homeless, elderly, and vulnerable populations. Ensuring the safety and security of the occupants within a workhouse is of paramount importance. Among the various risks that need to be addressed, fire incidents pose a significant threat to both life and property. Therefore, implementing effective fire safety measures and robust security protocols is crucial for workhouse management. Traditional Fire Safety Systems: Traditional fire safety systems in workhouses typically consist of basic smoke detectors, fire alarms, and manual evacuation procedures. While these systems have been relied upon for years, they often fall short in terms of early detection, prompt response,

and efficient management. Manual observation and delayed notification can lead to catastrophic consequences in the event of a fire. Additionally, unauthorized access to restricted areas within the workhouse poses security risks and compromises the safety of residents and staff. The Need for IoT-Based Solutions: To address the limitations of traditional fire safety systems, there is a growing need for innovative solutions that leverage the power of the Internet of Things (IoT). IoT technology allows for the integration of interconnected sensors, real-time data communication, and intelligent algorithms to create a comprehensive fire alarming and authentication system for workhouses. By harnessing the potential of IoT, workhouse management can enhance fire safety measures, improve response times, and strengthen security protocols. Objectives of the System: The primary objective of the IoT-based fire alarming and authentication system for a workhouse is to provide an advanced and integrated solution for fire safety and security. The system aims to achieve the following objectives: a. Fire Detection and Alarming: Develop a network of interconnected sensors to monitor environmental parameters such as

temperature, smoke, and gas levels. Implement advanced algorithms for accurate and prompt detection of fire incidents. Trigger immediate alarms to alert occupants and initiate evacuation procedures. b. Rapid Response and Notification: Automatically notify relevant authorities, such as the fire department, in the event of a fire. Enable swift response and minimize potential damage by ensuring that emergency services are promptly informed. c. Access Control and Authentication: Implement robust authentication mechanisms, such as smart cards or biometric data, to control access within the workhouse. Verify the credentials of authorized personnel at designated access points to prevent unauthorized entry and enhance security. d. Centralized Management and Control: Establish a centralized control unit to process and analyze data from the sensors, monitor the status of the system, and facilitate efficient management and maintenance. Enable remote monitoring and control for enhanced convenience and flexibility. e. Data Analysis and Optimization: Collect and analyze data from the system to identify patterns, optimize fire safety protocols, and address potential vulnerabilities. Utilize the insights gained

from data analysis to continuously improve the system's performance and effectiveness.

Structure of the Document: This document presents a comprehensive overview of the IoT-based fire alarming and authentication system for a workhouse. The subsequent sections will delve into the existing challenges, the proposed system architecture, the key components of the system, the implementation details, and the expected benefits. Additionally, the document will discuss the potential impact of the system on workhouse safety, security, and operational efficiency. The insights provided in this document aim to shed light on the significance of the IoT-based solution and its potential to revolutionize fire safety and security measures in workhouses.

Significance of IoT-Based Solutions: The integration of IoT technology in the context of fire safety and security systems brings numerous advantages. By utilizing interconnected sensors, real-time data communication, and advanced analytics, the IoT-based fire alarming and authentication system offers a more proactive and efficient approach to mitigate fire risks and enhance security in workhouses. This technology allows for continuous monitoring, immediate

detection, and prompt response, reducing the potential for damage and increasing the safety of residents and staff.

Improved Fire Detection and Alarming: The IoT-based system leverages a network of sensors strategically placed throughout the workhouse to detect changes in environmental conditions. These sensors can accurately identify the presence of smoke, abnormal temperature variations, and hazardous gases associated with fire incidents. The real-time data collected by these sensors is processed and analyzed in the central control unit, enabling rapid detection of fires and triggering immediate alarms to alert occupants and initiate evacuation procedures.

Enhanced Response and Notification Mechanisms: The system ensures a swift response to fire incidents by automatically notifying relevant authorities, such as the fire department, upon detection of a fire. This automated notification system significantly reduces response times and facilitates a coordinated and efficient firefighting effort. Additionally, the system can provide real-time updates to occupants, directing them to safe evacuation routes and ensuring their well-being during emergency situations.

Strengthened Access Control and

Authentication: Access control plays a vital role in maintaining the security and integrity of a workhouse. The IoT-based system incorporates robust authentication mechanisms to prevent unauthorized access to restricted areas. By utilizing smart cards, biometric data, or other authentication methods, only authorized personnel can gain access to specific zones within the workhouse. This enhances security, protects valuable assets, and ensures the safety of residents and staff.

Centralized Management and Control: The centralized control unit serves as the backbone of the IoT-based system, providing a centralized management and control interface for monitoring and maintaining the system. Workhouse management can remotely monitor the status of sensors, access control points, and other components of the system, allowing for efficient troubleshooting and maintenance. Additionally, the central control unit facilitates the integration of additional features or functionalities, ensuring the scalability and adaptability of the system.

Data Analysis and Optimization: The IoT-based system collects vast amounts of data from the sensors and other system components. This data can be analyzed to

gain valuable insights into fire incidents, patterns, and potential vulnerabilities. By leveraging advanced analytics techniques, workhouse management can optimize fire safety protocols, identify areas of improvement, and proactively address any risks or deficiencies in the system. This data-driven approach allows for continuous optimization and ensures the system's effectiveness over time.

Conclusion: In conclusion, the IoT-based fire alarming and authentication system presents a groundbreaking solution for addressing fire safety and security challenges in workhouses. By integrating IoT technology, the system enhances fire detection, response, and evacuation procedures, while also strengthening access control and authentication mechanisms. The centralized management and data-driven optimization further contribute to a safer workhouse environment. The subsequent sections of this document will delve deeper into the system architecture, implementation details, and expected benefits, providing a comprehensive understanding of the IoT-based solution's potential impact on workhouse safety and security.

BLOCK DIAGRAM

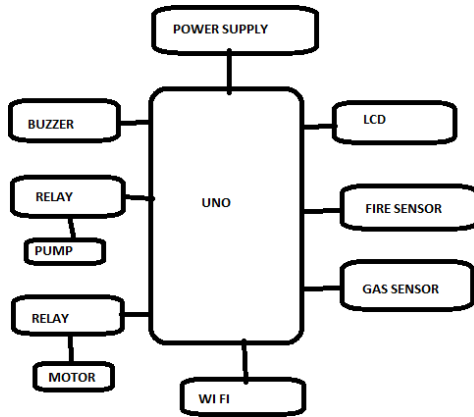

FLAME SENSOR: A flame detector is a sensor designed to detect and respond to the presence of a flame or fire. It also can detect ordinary light source in the range of a wavelength 760nm-1100 nm. The detection distance is up to 100 cm.



Fig : Flame Sensor

GAS SENSOR: MQ-2(HYDRO CARBON) This CO₂ Sensor can be used in a wide range of applications, including air quality monitoring, smoke alarms, mine and tunnel warning systems, greenhouses, etc.

The sensor is easy to use and can be easily incorporated in a small portable unit.



Fig: Gas Sensor

CONCLUSION In this paper, we discussed the latest technology that can help to reduce catastrophic accidents caused by fire. We designed the whole system and evaluated its effectiveness as well as scalability. With the improvement of sensor technology, the system will become more efficient and useful. If this system can be successfully integrated in every factories, then it is hoped that the loss of life and property due to the fire accidents will reduce remarkably and the country's economy will not be stumbled by such tragic accidents. Also the system is compact and can be implemented with low cost. With the help of the images sent to the email, investigation to find the cause of fire can be determined better and it can be used as evidence to claim insurance.

FUTURE SCOPE This system has a wide range of uses in various fields, such as

schools, offices, factories, power plants, etc... The reason this system is quiet useful is due to the fact that it is highly compact and it provides fire alarming and authentication system.

REFERENCES

- M. S. Obaidat, and P. Nicopolitidis, "Smart Cites and Homes: Key Enabling Technologies", Elsevier, 2016.
- Wilson Feipeng Abaya , "Low cost smartsecurity camera with night vision capability using Raspberry Pi and OpenCV" Electron. & Commun. Eng. Dept., De La Salle Univ., Manila, Philippines
- S. Tanwar, P. Pately, K. Patelz, S. Tyagix,
- N. Kumar, and M. S. Obaidat, "An AdvancedInternet of Thing based Security Alert System for Smart Home", IEEE 2017
- Manish Kumar, Shubham Kaul, Vibhutesh Kumar Singh and Vivek Ashok Bohara, "iDART- Intruder Detection and Alert in Real Time", India Innovation Initiative - i3, 2015, pp. 126-132.