



International Journal of HRM and Organizational Behavior



www.ijhrmob.com

editor@ijhrmob.com

Controller Design and Implementation of Solar Panel Companion Inverters

K.Madhavilatha¹, K.Anusha²,B.Akhil³

¹Associate Professor,Department of EEE,BRILLIANT GRAMMAR SCHOOL EDUCATIONAL SOCIETY'S GROUP OF INSTITUTIONS-INTEGRATED CAMPUS Abdullapurmet (V), Abdullapurmet (M), R.R Dt. Hyderabad.

²Assistant Professor,Department of EEE,BRILLIANT GRAMMAR SCHOOL EDUCATIONAL SOCIETY'S GROUP OF INSTITUTIONS-INTEGRATED CAMPUS Abdullapurmet (V), Abdullapurmet (M), R.R Dt. Hyderabad.

³UG Student,Department of EEE, BRILLIANT GRAMMAR SCHOOL EDUCATIONAL SOCIETY'S GROUP OF INSTITUTIONS-INTEGRATED CAMPUS Abdullapurmet (V), Abdullapurmet (M), R.R Dt. Hyderabad.

Article Info

Received: 11-07-2022

Revised: 11 -08-2022

Accepted: 05-09-2022

ABSTRACT:

Solar Panel Companion Inverter (SPCI) is a single stage DC-AC power converter, installed with each solar panel. Each SPCI synthesizes an AC quasi-square wave voltage with variable pulse width. Width of AC output voltage of each SPCI is proportional to available power on the solar panel. Output voltages of SPCIs are aggregated across multiple solar panels connected in series, and a sinusoidal AC voltage is synthesized. In this paper, dynamic analysis and closed loop current controller design of SPCI is presented. Simulation results demonstrating the dynamic response of the closed loop SPCI are included. The closed loop current control scheme is implemented on a hardware prototype to demonstrate the grid tied operation of SPCI, and experimental results are presented. Maximum Power Point Tracking (MPPT) algorithm is implemented for Sorted Stair-Case Modulation (SSCM) in MATLAB Simulink. Experimental results demonstrating MPPT operation are presented

Keywords: SSCM, MPPT, SPCI, AC.

1. INTRODUCTION

Main photovoltaic or pave inverters had been advanced for programs involving massive-scale power technology so that it will optimize investment prices of strength electronics on a according to-watt basis [1-3]. Photovoltaic panel strings are built centrally by using connecting individual panels in collection to build up DC voltage. These threads are then connected together to scale up to the desired energy stage and fed right into an unmarried relevant inverter. A DC-DC energy conversion step might be added earlier than the DC-AC conversion to supply a version of the centralized geography. Either the string level or the panel degree can use the DC electricity conversion degree [4, 5]. The string inverter topology is a boosted version of the principle inverter design [6] in this structure; panels are related in strings immediately to an inverter, which is then linked to the a/c electricity grid. Due to the truth that they only method strength from one string, string inverters are smaller than principal inverters. One opportunity is

to apply a micro-inverter for each sun panel [4]. These tiny inverters convert the DC strength generated by means of a single sun panel and create the important air conditioner voltage. This topology has the extra benefit of scaling close to the required power degree because of its modularity. In order to match the grid voltage level, micro-inverter geography necessitates a further energy conversion segment to step up the component voltage of sun panels (typically 30-35 V DC at perfect energy aspect technique). The system reports large losses as a result of the extra DC-DC energy conversion degree. In addition, when compared to major and string inverter architectures, the charge consistent with watt for micro-inverter topology is the very best. Each Photo Voltaic (PV) issue could have its specific modern-voltage (I-V) and electricity-voltage (P-V) characteristics for the given working situations of sunshine and temperature. To make sure ideal usage of the PV modules in any form of PV

inverter layout, it is crucial that all PV components are operated at their respective top of the line strength factors. To make sure that the quality electricity elimination from PV inverters is possible, MPPT algorithms along with Perturb and Observe (P&O) or incremental conductance may be used [7–16]. Voltage-mode manage and present day-mode manipulate are possible strategies for handling the grid-connected PV inverters. Versatile AC Transmission System (FACTS) controllers have genuinely used voltage-mode control [17–20]. In this mode of control, the stage angle and amplitude of the inverter output air conditioner voltage are adjusted with regards to the voltage on the element of commonplace combining to regulate the real and responsive power (PCC). The downside of voltage-mode control is that the AC grid present day cannot be explicitly controlled, leaving the inverter vulnerable to issues like over currents. [21] The air conditioner grid contemporary of the inverter is without delay managed within the modern-day putting control. By adjusting the stage attitude and amplitude

of the a/c grid relative to the voltage at PCC, both active and reactive strength are regulated in this manner. This ensures that the inverter is covered from surprising modifications in the cutting-edge. Additionally, this approach has the advantages of being strong and having exceptional dynamic performance. [21, 22] The manage loops regularly involve a contrast of sinusoid ally various parameters. Such loops might also have proportional-crucial (PI) or proportional-resonant (PR) controllers (PR). To acquire a no stable state mistakes without changing the reference body, it's miles hard to implement PI controller to manage the on the spot price of sinusoidal gift [23]. However, due to the fact to its high-quality gain at fundamental regularity, public members of the family controller can acquire a circumstance wherein there may be really no room for blunders. [24] In order to realize panel-degree MPPT even as simultaneously playing the gadget-stage fee blessings of an important inverter, photovoltaic panel companion inverters (SPCIs) have been proposed as a brand

new solution [25]. While most important inverters, string inverters, and micro inverters might also use two-stage electricity conversion to increase yield, SPCI is an unmarried phase strength conversion tool. Even though there are various multilevel inverter topologies available, which include diode secured and flying capacitor topologies, those have the downside of now not being modular and having tough manage execution [26], [27]. Although SPCI is a multilevel inverter structure as nicely, it is modular and does not require an advanced manage method like diode clamped or flying capacitor geometries do. Unsorted Pulse Size Modulation (UPWM), Sorted Stair-Case Inflection (SSCM), and Sorted Pulse Size Modulation (SPWM) have all been discussed in previous paintings, and the proposed SPCI device has definitely been managed in an open loop in order that simplest actual strength flows into the grid at cohesion power detail. The MPPT algorithm has been used to demonstrate MPPT on the panel stage in addition to active and responsive power capabilities.

[28] - [30] Although closed loop modern-day control became used in later indicators, the point of interest has been on proving the MPPT operation, and much less interest has been paid to the controller evaluation and design of grid linked SPCIs. The format and operation of the controller for the grid-linked SPCI are offered on this paper in first rate element. The primary contribution of these paintings is Area III, and is the reason the design of the used manage plan. There is evaluation like the one furnished in [21]. In order to demonstrate the close loop present manage of grid connected SPCI, simulations are run in MATLAB Semolina. For each simulations and hardware implementation, the MPPT approach has been used alongside closed loophole gift control operation to illustrate the maximum strength technique.

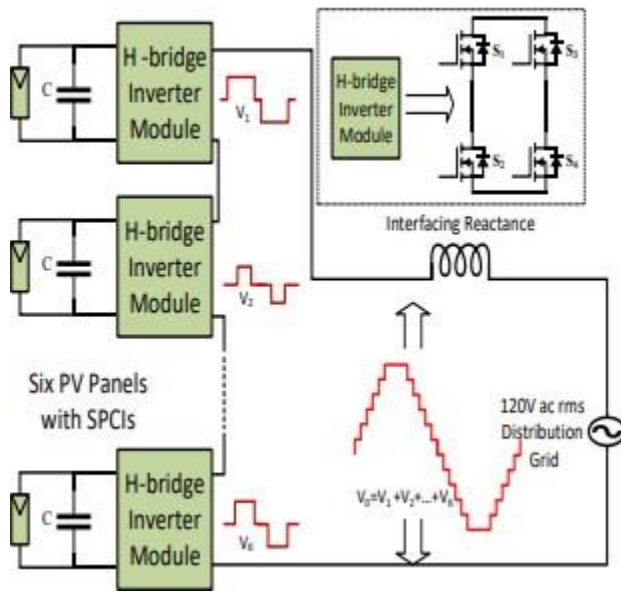

Fig.1. Block diagram.

2 LITERATURES SERVEY

In the preceding phase, we discussed the essential framework for harnessing the sun's energy the use of sun-powered forums. This discussion mentioned the overall standards and assumptions underlying the machine. We shall study a part of the noted IEEE reference documents in this phase. Where information on the numerous versions, systems, and improvements that were formerly used for producing energy from the sun is displayed. It additionally consists of the precise technique that became applied to the utilization of sunlight-

powered energy. A mission has been submitted by means of Luis Armed et al [1]. The recognition of this have a look at is the introduction of a photovoltaic duration framework that uses daylight as its source of power as general electricity cellular for micro grid packages. The suggested shape is appropriate for supplying supply security via dispensing ongoing strength to conventional loads in an independent manner and switching seamlessly among live single and matrix linked mode. The structure's energy circulate is adjusted using a probably the greatest 20kWh lithium-ion battery to lessen the impact of the building's age and cargo demand changeability. This essay gives an outline of the apparatus, hints for manipulate measures, and framework-based totally leisure models. Regardless of the strength that a reliable strength supplies may provide. Expanding electricity safety is in high call for. Dodd power safety refers back to the ability to ensure and provide sufficient electricity to deal with operational difficulties similarly to having guaranteed get right of entry to dependable

strength sources. In this way, lengthy-time period power resources and energy garage components play a critical function in selling the improvement of backup electricity assets, which can be now confounded through diesel turbines. The unpredictability of the electricity source, including solar and wind energy, and the stochastic character of the weight, are the primary standards for figuring out whether or not an extended-time period source of power may be capable of cover the space in dependable assets of power. However, the introduction of latest strength storage additives with more strength storage capability, such as superb-capacitors, lithium-ion batteries, and movement batteries, opens up the possibility of communicating a sustainable source of power that is ready to function independently in addition to easily transition from a matrix disengaged to a latticework related mode of operation. The development of a sun compact range useful resource with a lithium-ion battery is the primary attention of this text. The fundamentally counseled viewpoint of this

shape is suitable for providing deliver protection through conveying continuous strength to essential masses in an unbiased manner. However, the framework's lack of ability to seamlessly transition from off-lattice to matrix is one of its shortcomings. According to Yu-Jen Liu et al. [2], a solar inverter—which is answerable for reworking power—is an essential element utilized in daylight-based photovoltaic power systems. The operation of photovoltaic or pave inverters is the concern of many worries in view that even worse situations ought to have devastating outcomes on the security, implementation, and matrix interconnection capabilities of sun-based totally solar energy structures. A uniform fashionable, called IEEE 1547 ordinary, is offered by way of IEEE SCC21 for electrical power structures' interconnection with distributed belongings considerations. The preferred concentrates on the unique selections and consists of fundamental requirements, responses to uncommon problems, manage high high-quality, islanding, and take a look at guidelines, as well as wishes for approach,

introduction, established order evaluation, charging, and habitual testing. Because of the IEEE 1547 popular, this have a look at affords an automatic PVI connectivity check shape. The technical necessities that explain the DER association objects have to be satisfied earlier than coming into the marketplace are proven within the IEEE 1547 setup of benchmarks. These ideas additionally play a widespread position in some countries' advent of stunning matrix methods because of the mixing of numerous interconnected DER frameworks. The proposed PVI association test framework by and large includes DC manipulate resource, device underneath exam (EUT), AC control source, RLC pile, data security, observation, and examination structure. The maximum stringent check constraint is based totally on 30 kW, and it's far a mechanized check shape. The foremost benefit of this framework is that it is able to supply the highest input voltage of 360–four hundred V as well as the very best input strength of 4700 W. The downside of the IEEE 1547 primary setup is that it presents instructions for

describing the affiliation necessities. Sun-primarily based inverters are designed mainly to control sun (PV) forums, efficiently isolate the largest amount of electricity, and legally rework it so it can be infused into the matrix. The utility's selfhoods look at possibilities that would be abused for extra execution. PV inverters are designed to perform at low voltage ranges, almost at a hard and fast frequency, and with an energy consideration this is usually higher than zero. Eight. Keeping in mind these inverter-particular characteristics, a specific geography is recommended. This paintings' novel topology affords notable operational characteristics close to five-stage geography. Only some extra electricity-digital sectors are wanted for a 3-stage topology as a way to attain this result. The anticipated and applied structure is a 3-level one general. Its outstanding performance is proven, and its benefits and restrictions are emphasized. By implementing a low-manipulate inverter framework with the cautioned topology, the viability of this novel geography is also

explored. The most first rate element of those traits is that PV inverters are made to work at low voltage settings, basically without recurrence, and also with a energy parent this is typically extra common than 0.8. These unusual features provide the chance to develop a details inverter that satisfies the necessities of being sincere whilst despite the fact that being outstanding. In order to supply a sinusoidal wave with low bending, there are most important correlative hard replacing processes to use: (1) a excessive reoccurrence PWM, and (2) setting the variety of DC voltage ranges that the inverter generates (multilevel inverters). The call for faster power devices, like huge-band hollow gadgets that can be pushed at such excessive frequencies, as well as for quicker and more intense microcontrollers with a selected goal to achieve dependable dynamic tracking of complex systems, like daylight-based totally inverters, gift two fundamental boundaries to growing the replacing frequency. The predominant gain of this framework is that a unique clean

geography that simulates a five-diploma topology in phrases of execution was recreated and also provisionally accepted. The disadvantage is that because of the geography, converting the capacitors requires an extra circuit. To replace the capacitors, an unmarried complete-extension DC-DC converter is recommended. The authors of this work are Antonio Ginart1 and others. [3] Tai-Hung Wang Chen Liu and others [4] has added established an address the evaluation and implementation of a cascade-miniaturized DSP-primarily based framework linked to a sun-powered scale inverter. A cascade-circuit design connects the proposed solar-primarily based inverter with maximum severe power point compliance (MPPT) task to the air con network. High makeover overall performance, excessive MPPT exactness, and additionally low symphonious turning can be reached due to the concentrated single-prepare manage change. A 300W studies observe centre version turned into advanced, and it changed into tried to verify the validity of the advised idea. The development of

lengthy-lasting strength assets such electricity plants, solar cells, and wind generators has attracted interest from many angles. Future economic development is further impacted by means of the expansion of related activities. The parallel backend matrix frameworks for modules and the solar-oriented cellular forums deliver strength charges are two top notch worries for the sun strength structures.

Semiconductor Field Impact Transistors (MOSFETs), one DC web hyperlink capacitor, one microcontroller, and a parasitical power supply that draws power immediately from the photovoltaic panel make up each H-bridge inverter factor. The sun panel is incorporated with the inverter module (for that reason the time period Photovoltaic panel Friend Inverter), and relying on the DC voltage of the panel, a quasi-rectangular wave of the required period or a pulse width regulated waveform of known as-for pulse-width is produced. This is completed using a type and pile calculation that also takes variance in sun panels' irradiation ranges into account. Numerous such panels and their partner inverters are connected in collection to decide the necessary air conditioning voltage. The electricity circuit to create a 120V zircon ram's voltage is proven in Fig. 1. It includes six panels, every of that is capable of generating a DC voltage of about 35V, related in series with the corresponding friend inverters and related to the circulate grid thru a seclusion transformer. The distribution grid voltage

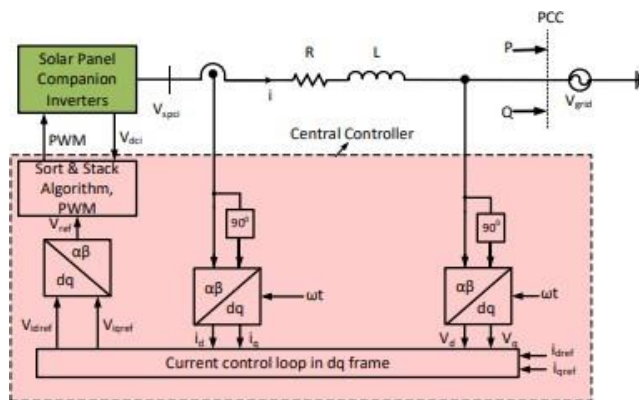

3. OVER VIEW OF PROPOSED SYSTEM

The SPCI (Photovoltaic Panel Buddy Inverter) and the plunging H-bridge multilevel inverter are topologically identical. However, it is essentially specific in the way wherein it is used. Four strength electronics devices, ideally Metal Oxide

and the voltage fall due to the interface reactance each have an impact on the scale of the output AC waveform, V_0 , so as to be produced through the PV production gadget.

Closed loop control system described by (32) and (33) has been built in MATLAB Simulink, to study the step response of the system. The input to the system is id_{ref} and output is id . The system is subjected to following sequence of events: id_{ref} is initially set to the 19.5 (which is the rated id value) until 0.15 s. At $t = 0.15$ s, id_{ref} is subjected to a step change from 19.5 to 10.

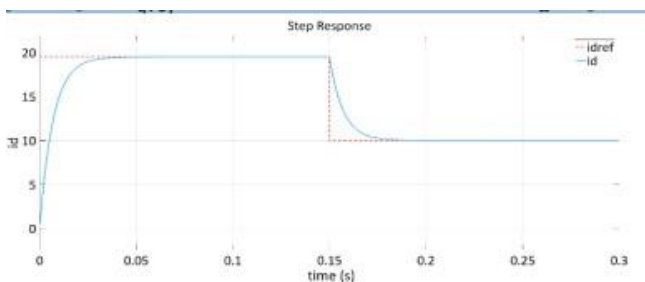

Fig. illustrates the time response of the system to the changes in the input signal. It may be seen that id tracks the id_{ref} . The step response of id is a first order exponential function that reaches its final value after about 0.05 s. As the control

loops along d -axis and q -axis are same, the step response of iq when subjected to a step change in iq_{ref} would also be the same as that of id response.

4. SIMULATION RESULTS:

It may be found that the grid voltage, "Grid," and the grid contemporary, "Ingrid," are in phase with one another. The thirteen-degree output voltage produced by means of the SPCI is called "Aspic." The simulated waveforms of air conditioner portions measured for reactive electricity injection are shown in Figs. Nine's and nine's. Given that responsive electricity is currently being delivered to the grid collectively with energetic power, it may be seen that the grid's existing (Ingrid) and voltage (Grid) aren't in phase. The grid current's strength need to observe from the strength of the reactive and active additives of the current. Additionally, it may be seen in all 3 picas that the SPCI's output voltage differs from the grid voltage in terms of size and phase perspective. This monitoring is justified by (1), which indicates that "Aspic" is each the voltage

troop throughout the interfacing reactance and the pharos amount of "Grid."

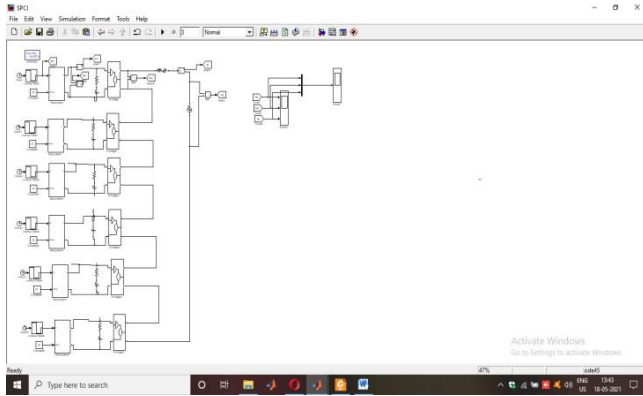

Fig. 7. Simplified circuit schematic of Solar Panel Companion Inverters (SPCI), with ideal DC voltage sources on the DC terminals and connected to a 120 V AC rams distribution grid.

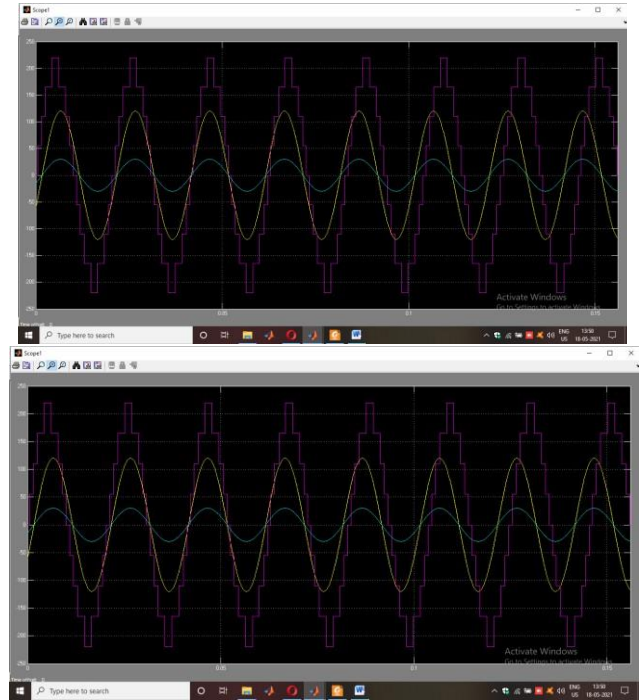

Fig. 9. Simulation results showing AC waveforms on the grid side of Solar Panel Companion Inverters (SPCI), with ideal DC voltage sources connected to the DC terminals of each H- bridge module.

- a. Reference currents along d-axis and q-axis are set to 17A and 0 A respectively.
- b. Reference currents along d-axis and q-axis are set to 17A and 5 A respectively.
- c. Reference currents along d-axis and q-axis are set to 17A and 8 A respectively.

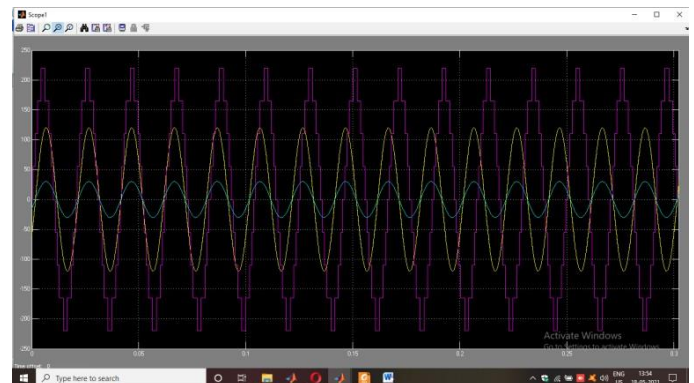
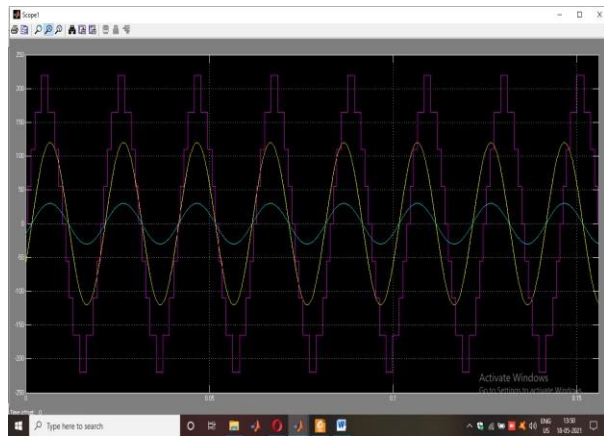

Fig. 16. Simulation Results when all panels are operating under scenario 4 (950 W/m², 800 W/m², 650 W/m², 500 W/m², 350 W/m², 200 W/m²), with Maximum Power Point Tracking (MPPT) algorithm implemented for Sorted Staircase Modulation (SSCM); a. P-V curves

showing the maximum power point operation of all the PV panels highlighted in red, b. Simulation Waveforms of grid voltage, Grid, inverter output voltage, Aspic, and, grid current, Ingrid.

CONCLUSION:

Dynamic analysis and closed loop control design for grid connected SPCI has been performed. Simulation results demonstrating the dynamic response of the grid connected SPCI with DC voltage sources connected across the DC terminals of SPCI have been presented. Experimental results demonstrating closed loop current control operation of grid connected SPCI (with six SPCIs) have been included as well in the paper. MPPT together with closed loop current control algorithm has been used to demonstrate maximum power operation of SPCI. Simulations have been performed to demonstrate MPPT, by employing Sorted Stair-Case Modulation (SSCM). It has been demonstrated that the algorithm is able to extract maximum power from the system for both uniform and non-uniform irradiation. Experiments have been performed by connecting three real solar panels to a grid connected SPCI prototype with three SPCIs. MPPT

algorithm has been implemented on the three SPCI setup, and experimental waveforms captured during two different instants in a day have been presented.

REFERENCES

- [1] M. Díez-Mediavilla, M. Dieste-Velasco, M. d. C. Rodríguez-Amigo, T. García-Calderón, and C. Alonso-Tristán, "Performance of grid-tied PV facilities based on real data in Spain: Central inverter versus string system," *Energy Conversion and Management*, vol. 86, pp. 1128-1133, 2014.
- [2] Yang, Yongheng, and Frede Blaabjerg. "Overview of single-phase gridconnected photovoltaic systems." *Electric Power Components and Systems* 43, no. 12 (2015): 1352-1363.
- [3] Noor, SZ Mohammad, Ahmad Maliki Omar, N. N. Mahzan, and I. R. Ibrahim. "A review of single-phase single stage inverter topologies for photovoltaic system." In *2013 IEEE 4th Control and System Graduate Research Colloquium*, pp. 69-74. IEEE, 2013.
- [4] H. Bergveld et al., "Module-level DC/DC conversion for photovoltaic

systems," in Telecommunications Energy Conference (INTELEC), 2011 IEEE 33rd International, 2011, pp. 1-9: IEEE.

[5] A. Elasser, M. Agamy, J. Sabate, R. Steigerwald, R. Fisher, and M. Harfman-Todorovic, "A comparative study of central and distributed MPPT architectures for megawatt utility and large scale commercial photovoltaic plants," in IECON 2010-36th Annual Conference on IEEE Industrial Electronics Society, 2010, pp. 2753-2758: IEEE.

[6] L. Hassaine, E. OLIas, J. Quintero, and V. Salas, "Overview of power inverter topologies and control structures for grid connected photovoltaic systems," Renewable and Sustainable Energy Reviews, vol. 30, pp. 796- 807, 2014.

[7] Abdelsalam, Ahmed K., Ahmed M. Massoud, Shehab Ahmed, and Prasad N. Enjeti. "High-performance adaptive perturb and observe MPPT technique for photovoltaic-based microgrids." IEEE Transactions on Power Electronics 26, no. 4 (2011): 1010-1021.

[8] Sera, Dezso, Laszlo Mathe, Tamas Kerekes, Sergiu Viorel Spataru, and Remus

Teodorescu. "On the perturb-and-observe and incremental conductance MPPT methods for PV systems." IEEE journal of photovoltaics 3, no. 3 (2013): 1070-1078.

[9] M. A. Elgendy, B. Zahawi, and D. J. Atkinson, "Assessment of perturb and observe MPPT algorithm implementation techniques for PV pumping applications," IEEE transactions on sustainable energy, vol. 3, no. 1, pp. 21-33, 2012.

[10] S. Alsadi and B. Alsayid, "Maximum power point tracking simulation for photovoltaic systems using perturb and observe algorithm," International Journal of Engineering and Innovative Technology (IJEIT), vol. 2, no. 6, pp. 80-85, 2012.