



# International Journal of HRM and Organizational Behavior



[www.ijhromb.com](http://www.ijhromb.com)

[editor@ijhromb.com](mailto:editor@ijhromb.com)

## OFF-BOARD ELECTRIC VEHICLE BATTERY CHARGER USING PV ARRAYS

K. Lalaiah<sup>1</sup>, K.Shankaraiah<sup>2</sup>,K.Ramesh<sup>3</sup>

<sup>1</sup>Associate Professor,Department of EEE,BRILLIANT GRAMMAR SCHOOL EDUCATIONAL SOCIETY'S  
GROUP OF INSTITUTIONS-INTEGRATED CAMPUS Abdullapurmet (V), Abdullapurmet (M), R.R Dt.  
Hyderaba-501505

<sup>2</sup>Assistant Professor,Department of EEE,BRILLIANT GRAMMAR SCHOOL EDUCATIONAL SOCIETY'S  
GROUP OF INSTITUTIONS-INTEGRATED CAMPUS Abdullapurmet (V), Abdullapurmet (M), R.R Dt.  
Hyderabad-501505

<sup>3</sup>UG Student, Department of EEE,BRILLIANT GRAMMAR SCHOOL EDUCATIONAL SOCIETY'S GROUP  
OF INSTITUTIONS-INTEGRATED CAMPUS Abdullapurmet (V), Abdullapurmet (M), R.R Dt. Hyderabad.

### *Article Info*

*Received: 09-10-2022*

*Revised: 01 -11-2022*

*Accepted: 15-12-2022*

### **ABSTRACT:**

Study on renewable energy based Electric Lorry battery charging system is flourishing in the automobile market in the recent years. The intermittent nature of the renewable resource sources causes the grid linked renewable resource systems for Electric car battery billing applications. Therefore, an Electric Lorry battery charger making use of grid connected PV system is proposed in this paper. Off-board battery chargers need to be very carefully looked at this requirement for quick refuelling created a change in EV billing technology to focus on DC facilities. This theory makes use of fuzzy logic to control energy intake and also EV battery charger utilizing SEPIC as well as BIDC (Bidirectional) converter. The Fuzzy reasoning control is utilized to merge the advantages of stable current control and constant voltage control. Unclear reasoning is appropriate for such executions. This strategy will help design the dynamics of nonlinear systems. Simulink determined as well as executed the solar-power system using photovoltaic cells, DC-DC converters, batteries, as well as fuzzy reasoning controllers.

***Keywords: EV, DC, SEPIC, BIDC, PV system.***

## 1. INTRODUCTION

Technical improvement has genuinely altered format and taken brand-new annoying situations to resolve a chain of troubles. Every one year, logo- new capabilities are delivered to cars. Security structures and manipulate functions absorb electric powered power even if engines are off. Battery p.C. May be placed indoor or outdoor the auto (off- board). An off-board charger is advanced to promote fast charging. This is certainly hundreds just like filling station. It offers an excessive output voltage. This can probable be the suitable desire for industrial use. Implementing this method might in all likelihood damage battery percent similarly to motive excessive energy call for. Due to upgrades in the solid- united states of America digital converters, photovoltaic structures have in reality turn out to be an enormous vacation spot for micro grids that produce electric strength through way of feeding electricity proper into the general grid throughout height hours. Photovoltaic systems may be hooked up in families to deliver charging stations for electric powered vehicles. Battery chargers are

mainly cut up proper into unmarried-stage and additionally -degree designs. Single-degree topology has the gain of lower weight, low amount, streamlined layout, and additional overall performance. Battery structures are categorized into 1/2 of of-bridge, complete bridge, multilevel, and separated AC-DC.

Ever in advance than developing results of greenhouse gases from the same old IC engines reason ecological problems. This paved to the thriving of infection complimentary electric powered cars (EVs) in the vehicle market. Nonetheless, EV battery charging from the application grid will boom the load name for at the grid similarly to in some unspecified time in the future increases the energy prices to the EV proprietors which necessitate the use of opportunity power belongings. Due to limitless and moreover contamination complimentary nature of renewable beneficial aid property (RESs), it could be carried out to bill the EV battery. Hence, RES driven EV can be defined as 'green transportation'. Solar is just one of the encouraging RESs which can be and not using a trouble touched to apply its

energy to charge EV battery. Therefore, PV range energy is implemented to bill the EV battery in the proposed device with the assist of power converter topologies. Lithium ion batteries are normally carried out inside the EV because of its excessive electricity density, immoderate overall performance, light-weight in addition to compact size. Also, those batteries have the functionality of short charging similarly to prolonged lifecycle with decreased self discharge price.

## 2. LITERATURE SURVEY

They moreover have low danger of explosion if its miles over charged or short circuited. Throughout charging, those batteries want correct voltage manage. For this cause, wonderful electricity virtual converters with voltage controller are utilized for charging EV battery. Because of the recurring nature of the PV variety, there's a call for energy converters to rate the EV battery. Among distinct converters, multiport converters (MPCs) are preferred within the onboard chargers of crossbreed EVs due to its potential of interfacing source of strength and power garage factors like PV selection, ultra capacitors, significantly capacitors, gas cells and batteries with the loads in EV like motor, lighting, electricity doorways and windows, radios, amplifiers as well as mobile

telephone charger. The MPCs have the drawback of upward thrust in weight, rate as well as maintenance of the EV as all of the sources are positioned within the EV itself. Additionally, the intricacy of controller implementation will increase in this converter-primarily based EV battery charging gadget. Therefore, an off-board charger is usually advocated in this paper wherein the EV battery is located within the vehicle unit further to PV choice and decrease lower back-up battery financial institution are positioned within the charging terminal or automobile park station. Various converter topologies for off-board charging machine exist inside the literature. Amongst distinct converter topology, the SEPIC converter is desired because of its potential of operating in every increase and additionally greenback modes. It likewise has the advantage of the very identical input and also output voltage polarity, low enter present ripple and low EMI. Nevertheless, throughout reduced sun irradiation and non sunshine hours, there can be a demand for a similarly garage battery financial business enterprise to charge the EV battery. This lower back-up battery monetary group needs to be charged within the in advance commands and additionally discharged in an opposite instructions depending at the solar irradiation. For this cause, a bidirectional converter with electricity float in both

commands is called for. The bidirectional converters are identified proper into non-isolated similarly to separated converters. Transformer in the remote converters gives seclusion which enhances the charge, weight and additionally length of the converter. The foremost problems of EV are weight and size and additionally therefore, non separated bidirectional converters are notable match for this software program.

Santhosh, T.K., Govindaraju, C.: 'Double input double final effects power converter with one-step-in advance manages for crossbreed electrical lorry applications. The quick conversion of automobile device masses to the electrical place name needs a strength converter to interface in among the on-board supply and moreover garage systems with the add-ons. This observes suggests a simplified framework of twin input dual end result (DIDO) with single-stage strength conversion for hybrid electric powered vehicle accent applications. Shukla, A., Verma, K., Kumar, R.: 'Voltage-hooked up modelling of speedy charging electric powered lorry load thinking about battery attributes': Electric vehicle (EV) assimilation proper into the power grids is enhancing quick. To look at the result of charging of EVs at the move tool, the general public of the literature thought about EV masses as constant strength lots (CPL) which do not stand for the ideal behaviour of those

uncertain hundreds. A specific EV lots modelling is created thru identifying the connection in between strength intake with the aid of EV, grid voltage in addition to us of a of prices of fast charging EV masses.

Wirasingha, S.G., Emadi, A.: 'Pihef: plug-in crossbreed electric factor', The capacity of plug-in hybrid electric lorries (PHEVs) to run in electric as well as hybrid modes in addition to their functionality to supplement the energy storage area off the grid have made them at the front-runner in alternative fuel automobile boom.

Kirthiga, S., Jothi Swaroopan, N.M.: 'Highly dependable inverter geography with an unique soft laptop method to remove leakage modern-day in grid-linked transformer an lousy lot a whole lot much less photovoltaic structures' Grid-related transformer an awful lot much less sun inverters are significantly fashionable inside the renewable useful resource market, on account of their high electricity thickness, inexpensive, and excessive effectiveness.

### **3. AN OVERVIEW OF PROPOSED SYSTEM**

The proposed PV-EV battery charger includes a PV variety, a sepic converter, a half-bridge BIDC, an EV battery, a backup battery financial institution and a controller as acquired Fig. 1 The controller is used to create eviction pulses to the sepic converter for acquiring the constant result voltage on

the dc net hyperlink. The gate pulses to the buttons of BIDC are likewise created to perform BIDC in increase mode to feed the back-up battery from PV array further to in greenback putting to charge EV battery from the again-up battery. Additionally, the controller creates the gate pulses to the complementary switches Sa, Sb in addition to Sc. During excessive solar irradiation, all the complementary switches are ON to client interface dc relate to PV choice thru the SEPIC converter, dc relate to the backup battery through BIDC and also dc link with EV battery. When solar irradiation is decreased, switch Sa is turned OFF setting aside the PV choice and SEPIC converter from the dc hyperlink. Whereas the button Sc is shut off to detach BIDC in addition to backup battery from the dc web link, while the sun electricity is insufficient to bill again-up battery. The cautioned gadget runs in 3 settings viz., mode 1, mode 2 and mode 3 as clarified on this area.

### **Mode 1.**

During top sunshine hours, while the produced PV range strength is greater, all the supporting switches are ON to price each EV battery and also backup battery on the same time from PV array with sepic converter and additionally BIDC, respectively. In this setting, BIDC runs in beforehand commands enhancing the dc net link voltage to bill returned-up battery.

### **Mode 2**

Reduced solar irradiation problems further to non-sunshine hours, PV variety energy are insufficient to price EV battery. Thus, the PV selection is separated from the dc link through switching off the button Sa and additionally modifications Sb & Sc get on linking EV battery to the back-up battery via BIDC. In this mode, BIDC runs backwards commands stepping down the backup battery voltage to invoice EV battery.

### **Mode 3**

When PV range power generated is sufficient to price best EV battery, modifications Sa and Sb get on as well as trade Sc is OFF to cut up the BIDC and backup battery financial institution from the dc hyperlink.

### **Circuit Layout:**

Where V Back-up Battery is the returned-up battery voltage in addition to D Increase is the obligation proportion of BIDC in enhance placing and D Buck is the greenback mode duty percentage. The worth of inductors are considered an awful lot less than the crucial inductance values in every beautify and greenback modes to run the converter in change transmission putting to enhance performance.

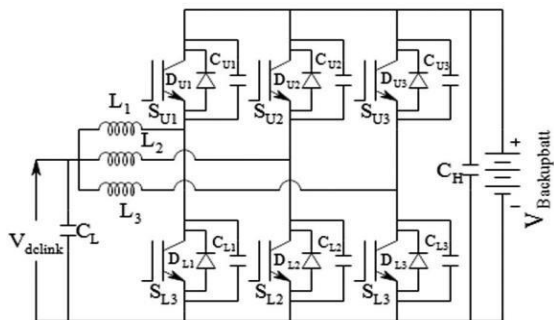

**Fig.3.1. BIDC circuit.**

**OPERATION SYSTEM:**

BIDC operates as boost converter in forward direction in this mode, boosting the dc link voltage,  $V_{dc}$  of 28 to 60.6 V to charge the backup battery with the increase in SOC as presented in below Fig.

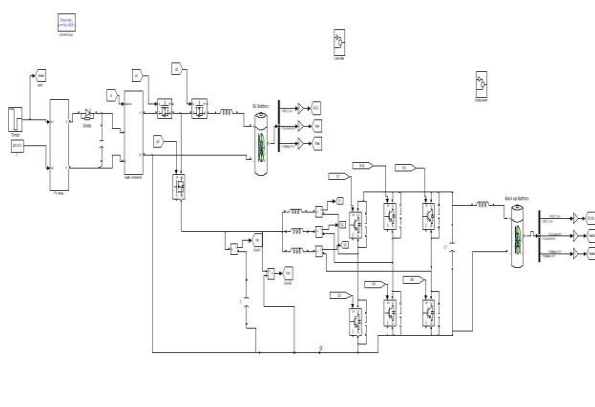

**Fig.3.2. Simulation circuit.**

In mode 2 (sooner or later of non-sunshine hours and also decreased irradiation problems), PV range is separated important to PV choice voltage,  $VPV$  elevating to its open circuit voltage of 37.25 V and additionally PV range cutting-edge,  $IPV$  of zero A, it's represented with the aid of the PV range voltage in addition to modern-day waveforms displayed in Fig. Three.2. During this period, BIDC runs in buck putting in

contrary instructions, stepping down the backup battery voltage to 27.32 V to price the EV battery as acquired Fig. 3.3.

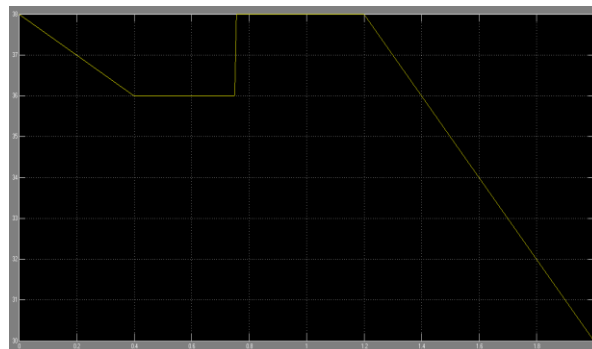

**Fig.3.3. PV Voltages across the output.**

The great present and minimize in SOC of backup battery proven in Fig. 3.4. shows that the lower back-up battery is launched in this mode. At the give up of this mode the back-up battery voltage is reduced to fifty five.2 V from 60.6 V as portrayed. Whereas in placing three, PV range voltage,  $VPV$  of 31.81 V is step all of the manner to a dc link voltage,  $V_{dc}$  of 27.6 V to rate the EV battery.

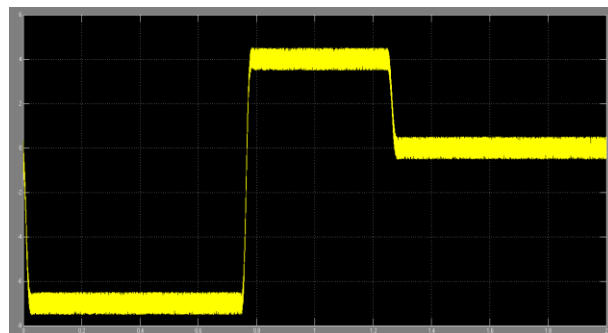

**Fig.3.4. Current across the backup battery.**

In this mode in addition, SOC of EV battery is boosting and contemporary misbehaves, indicating the charging of EV battery. In mode 3, because of the reality that

the back-up battery is separated from the charging tool, lower back-up battery voltage is maintained at its previous expense of fifty five.2 V and present day is decreased to zero.

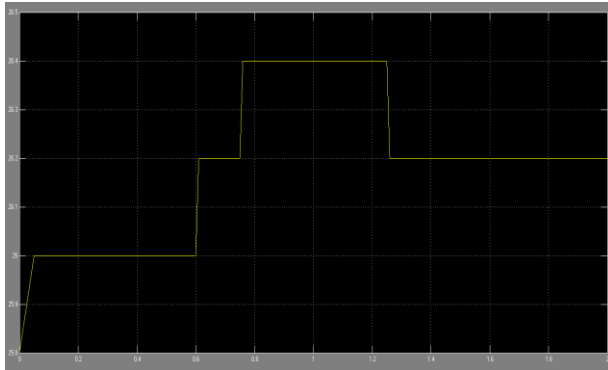

**Fig.3.5. Battery Voltage.**

The SOC of EV battery is elevating and also its present is unfavourable in all of the three modes showing that EV battery receives charged constantly either from PV variety or from backup battery. The interleaved inductor current waveforms of BIBC in all of the modules operandi. The turnaround of inductor existing glide in mode2 truly shows that the backup battery obtains discharged in this placing and also no inductor gift inside the putting.

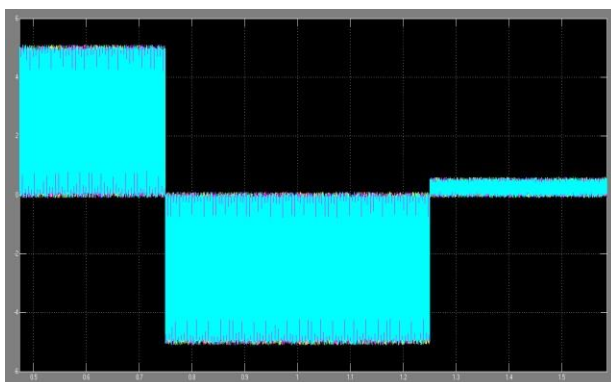

**Fig.3.6. 3 Phase currents.**

#### 4. CONCLUSION

In this task, an off-board EV battery charging system fed from PV array with blurry is generally advocated. This enterprise talks about the power of the device to fee the EV battery frequently no matter the irradiation troubles. The gadget is created in addition to simulated in Simulink environments of the MATLAB software. The blurry with PV simulation tested in laboratory for the three modules operandi of the recommended billing tool individually and the results are provided. Examination is carried out in RCP approach similarly to the colorful reaction of the device is obtainable each in simulation studies.

#### REFERENCES

- [1] Santhosh, T.K., Govindaraju, C.: 'Twin input dual output sturdiness converter with one-step-in advance control for hybrid electrical powered automobile packages', IET Electr. Syst. Transp., 2017, 7, (3 ), pp. One hundred 90-- hundred
- [2] Shula, A., Vera, K., Kumar, R.: 'Voltage-dependent modelling of rapid billing electric lorry thousands taking into account battery attributes', IET Electra. Syst. Transp., 2018, 8, (4), pp. 221-- 230.
- [3] Wirasingha, S.G., Meade, A.: 'Pie: plug-in hybrid electric powered difficulty',



IEEE Trans. Vet. Technol., 2011, 60, pp. 1279-- 1284.

[4] Kithira, S., Jodi Saroyan, N.M.: 'Very trusted inverter topology with an particular easy computing method to cast off leakage modern in grid-associated transformer less photovoltaic structures', *Compute. Electra. Eng.*, 2018, 68, pp. 192-- 203.

[5] Bradawl, M.O., Sober, Y.: 'Power flow control of a grid related PV-battery device for electric powered electric powered automobiles charging', *IEEE Trans. Ind. Appl.*, 2017, fifty three, pp. 1347-- 1357.

[6] Van Deer Meer, D., Chandra Moulin, G.R., Morales-Espurna Moulin, G., et al.: 'Energy administration device with PV power forecast to successfully rate EVs on the manage facility', *IEEE Trans. Ind. Inf.*, 2018, 14, pp. 311-- 320.

[7] Xavier, L.S., Cupertino, A.F., Pereira, and H.A.: 'Secondary services ready with the assist of photovoltaic inverters: solitary and three segments manipulate techniques', *Compute. Electra. Eng.*, 2018, 70, pp. 102-- 121.

[8] Kithira, S., Amambay Grounded, N.: 'Examinations of a complicated PV tool topology using multilevel beautify converter and line commutated inverter with solutions to grid problems', *Simile. Design. Pact. Concept*, 2014, 40, pp. 147-- 159.

[9] Suita, N., Kithira, S.: 'RES based totally completely EV battery charging gadget: an assessment', *Restore. Sustain. Power Rev.*, 2017, seventy five, pp. 978-- 988.

[10] Farina, H., Fotuhi-Firuzabad, M., Moeini-Aghtaie, M.: 'A practical plan to incorporate destruction price of lithium-ion batteries in automobile-to-grid bundles', *IEEE Trans. Sustain. Energy*, 2016, 7, pp. 1730-- 1738.

[11] Dubai, R., and Ibrahim, A., Sub has, M.: 'Multiinput DC-- DC converters in renewable electricity programs-- an outline', *Restore. Sustain. Power Rev.*, 2015, 41, pp. 521-- 539.

[12] Duong, T., Sajib, C., Yuanfeng, L., et al.: 'Maximized multiport dc/dc converter for cars and truck stress trains: topology and also style optimization', *Appl. Sci.*, 2018, 1351, pp. 1-- 17.

[13] Santos, T.K., Natarajan, K., Govindaraju, C.: 'Synthesis and moreover software of a multi-port dc/dc converter for crossbreed electric powered cars', *J. Power Electron.*, 2015, 15, (five), pp. 1178-- 1189.